

1224, 1229

4x2 Rigid Specifications

Atego

125! years of innovation



Mercedes-Benz
Trucks you can trust

Engine

Type	Mercedes-Benz OM 926 LA 7.2 litre turbocharged in-line 6 238 - 286hp (630 - 826 lb.ft) *Euro 5 with EEV (See Atego engines brochure for complete engine specification details)
------	--

Transmission

1224	
Type	Mercedes Benz G85 - 6/6.7 - 0.73 6 speed synchromesh transmission Mechanical gearshift
1229	
Type	Mercedes Benz G131 - 9/14.6 - 1.00 9 speed synchromesh transmission Mechanical gearshift

Clutch

Type	Self-adjusting single dry plate
Diameter	395 mm

Axles

Front	Mercedes-Benz 5,300 kg capacity
Drive	Mercedes-Benz 11,000 kg capacity Hypoid reduction 390 mm crown wheel Differential lock
Ratio	1224: 3.909 - 1,800 rpm @ 100 km/h 1229: 2.846 - 1,800 rpm @ 100 km/h

Suspension

Front axle	Mercedes-Benz 2 leaf parabolic springs Stabiliser bar and shock absorbers 4,400 kg capacity
Rear axle air	Mercedes-Benz 2 bag air suspension Stabiliser bar and shock absorbers 8,100 kg capacity Telligent® level control

Tank capacity

Diesel tank	1 x 325 litre rectangular aluminium tank on RHS
AdBlue tank	1 x 35 litre rectangular plastic tank on RHS

Chassis

Main rail	274 mm web x 65 mm flange x 7.0 mm thickness High strength E 380 TM steel Front Underrun Protection Device (FUPD)
Exhaust system	SCR catalytic converter with downswept outlet RHS

Brakes

Front/rear	Disc brakes 377 mm diameter Dual brake circuits Automatic adjustment Air dryer Load sensing brakes ABS (anti-lock brakes) ASR traction control
Engine brake	Active Engine Brake (AEB) with constantly open throttle valve

Cab

Type	S (Short) cab ECE-R29 compliant cab Driver's airbag and seatbelt pre-tensioner Multifunction steering wheel CD Radio with Bluetooth (See Atego Cabins brochure for complete cab specification details)
------	---

Steering

Type	Mercedes-Benz recirculating ball Integral power assistance Soft-feel 450 mm steering wheel Fully adjustable for height and rake
------	--

Wheels and tyres

Wheels	8-stud 8.25 x 19.5 steel wheels
Tyres	Steer - 265/70 R 19.5 Bridgestone R227 Drive - 265/70 R 19.5 Bridgestone M729

Electrical system

Voltage	24 volts
Batteries	2 x 12 V/115 Ah
Alternator	28 V/80 A
Starter	6.2 kW/24 V
Road lights	Halogen headlights
Fuses	Automatic fuses
Body Builder	Interface Module (PSM)

Atego 1224, 1229

4x2 Rigid Specifications

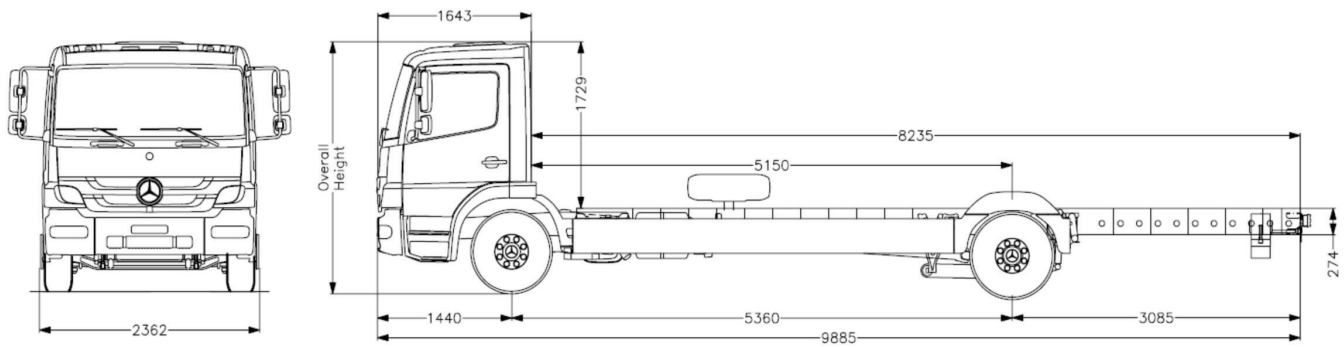

Note: Image above is a general arrangement drawing only. Contact your authorised Dealer for further details.

Weights

Tare	1224	1229
Front axle	3,125 kg	3,180 kg
Rear axles	1,550 kg	1,555 kg
Total	4,675 kg	4,735 kg
Plated weights	1224	1229
Front axle	4,400 kg	4,400 kg
Rear axles	8,100 kg	8,100 kg
GVM	11,900 kg	11,900 kg
GCM	16,390 kg	up to 28,000kg
Wheelbases	Wheelbase	Overhang
12XXL/54	5,360 mm	3,085 mm
12XXL/48	4,760 mm	2,685 mm
12XXL/42	4,260 mm	2,285 mm

Dimensions

Wheelbase	5,360 mm
Frame height at rear axle (unladen)	931 mm
Frame height at rear axle (laden)	892 mm
Overall height (unladen)	2,660 mm
Ground clearance front	215 mm
Ground clearance rear	170 mm
Cab tilt angle	55°
Turning circle (wall to wall)	19.4 m
Frame width at rear	854 mm

Dimension: Weights and dimensions shown are to specifications with no fuel, full AdBlue, oil, water and tools. Tare weights are subject to a manufacturing tolerance of ±3%. MBAuP reserves the right to alter specification or equipment without notice.

Options

- Axle ratio 3.077
- Trailer brakes
- High roof sleeper
- Telephone/Fax provision
- Long cab
- Extended short cab
- Air deflectors
- Rear side windows
- Wood trim dash
- Leather steering wheel
- CD storage box
- In cab cooler box
- Allison automatic transmission
- Extended fuel tank package
- Upright exhaust outlet
- Fog lights
- Painted bumper
- Painted grille
- PTO's
- 22.5" rims with 11R tyres
- Grammer, comfort, co-driver seat
- Centre seat with seatbelt
- 6 person seat/bunk combination
- Upper bunk

*Note: The OM 906LA 6.37 litre turbocharged inline- 6, 238 - 286 hp (630 - 826 lb.ft) engine is used in non EEV variants.

Authorised Dealer

To speak to your nearest authorised Mercedes-Benz Dealer call **1300 66 22 30**

For full Warranty details and limitations contact your authorised Mercedes-Benz Truck Dealer. IMPORTANT! This brochure has been compiled by Mercedes-Benz Australia/Pacific Pty Ltd to provide a general indication of the range of models available in Australia. Some of the models, features, optional extras and/or colours shown may not be available in Australia or may only be available in a different specification. Additionally, some models, features, optional extras and/or colours may only be available in combination with others. Some equipment depicted either on vehicle illustrations or separately may be non standard or options and may, where applicable, be available at an additional cost. For current information on the availability, design features and prices of all models, features, optional extras and/or colours available in Australia, you should contact your authorised Mercedes-Benz Truck Dealer on **1300 66 22 30** or go to www.mercedes-benz.com.au/trucks. All of the information contained in this brochure was correct as at April 2011. However, the manufacturer reserves the right to discontinue, make changes to design and specifications to vehicles or optional equipment without notice. Mercedes-Benz Australia/Pacific Pty Ltd. ABN 23 004 411 410. Lexia Place, Mulgrave, Victoria 3170. Ph: (03) 9566 9266. Facsimile: (03) 9562 0397. The and the words Mercedes-Benz, Telligent® and BlueTec® are registered trademarks of Daimler AG, Stuttgart, Germany.